

# MAE140 Linear Circuits (for non-electrical engs)

## Topics covered

### Circuit analysis techniques

Kirchoff' s Laws – KVL, KCL

Nodal and Mesh Analysis

Thévenin and Norton Equivalent Circuits

Resistive circuits, RLC circuits

Steady-state and dynamic responses

Impulse and step responses      Laplace transforms

Sinusoidal steady-state response

### Circuit design techniques

Active circuit elements – dependent sources and operational amplifiers

Feedback basics

Signal filtering – if we get time

# What do I expect you to know?

## Prerequisites

Mathematics 21D or 20D (some are doing this concurrently)

Solution of sets of linear equations

$Ax=b$  equations for vector  $x$  given matrix  $A$  and vector  $b$

Solution of constant coefficient linear ordinary differential equations

Laplace transform introduction

Initial conditions and forced response

Complex analysis

Numbers, arithmetic, magnitudes and phases, poles, zeros

Physics 2B

Behavior of circuit elements:  $R$ ,  $L$  and  $C$

Underlying physical principles

# Why should you be excited about MAE140?

Linear circuits are exceptionally well described by simple and powerful mathematics

The quality of concordance between measured physical behavior and mathematical description is amazing

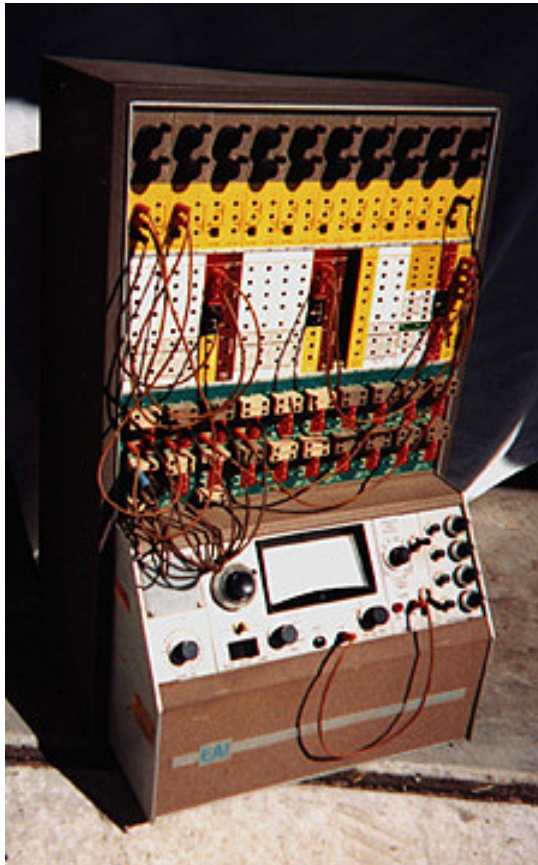

This is an analog computer from around 1963  
It was used to solve nonlinear ODEs via analog circuitry

It contained: about 20 integrators based on valves or transistors, some nonlinear function blocks using diodes, comparators

This was the state of the art for much physical system simulation

It relies on ideas underpinning MAE140

The tools of MAE140 are immediately useful in design

# Why should you still be excited about MAE140?

The *front and back ends* of your digital cell phone are comprised of analog circuits

This is pretty much true of all *digital* technology

Why does the stagecoach wheel appear to rotate backwards?

Aliasing

A high frequency masquerading as a low frequency

Anti-aliasing filters **MUST** be used in all sampled data systems

After MAE140 you will be able to start designing such anti-aliasing filters

The real thing!

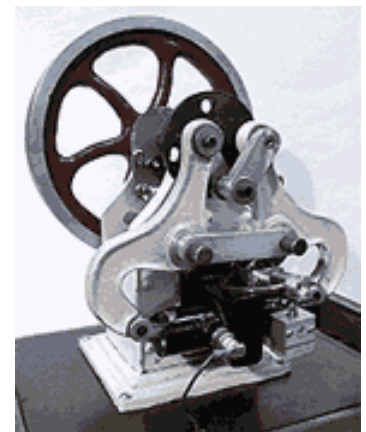

# Why should you still be excited about MAE140?

You will learn how these knobs and plugs work:



We will not have time to cover this one:





# Why should you still be excited about MAE140?

The Guardian article features a large mushroom cloud image from the 1966 B-52 crash. The article text states: "The bomb that nearly exploded over North Carolina was 260 times more powerful than the device which devastated Hiroshima in 1945. Photo: Three Lions/Getty Images". It further explains that a secret document reveals the US Air Force came close to detonating an atom bomb over North Carolina that would have been 260 times more powerful than the device that devastated Hiroshima. The document, obtained by investigative journalist Eric Schlosser, gives the first conclusive evidence that the US was narrowly spared a disaster of monumental proportions when two Mark 39 hydrogen bombs were accidentally dropped over Goldsboro, North Carolina on 23 January 1966. The bombs fell to earth

MAE140 Linear Circuits

“The bombs fell to earth after a B-52 bomber broke up in mid-air, and one of the devices behaved precisely as a nuclear weapon was designed to behave in warfare: its parachute opened, its trigger mechanisms engaged, and only **one low-voltage switch** prevented untold carnage.”

“... a senior engineer in the Sandia national laboratories responsible for the mechanical safety of nuclear weapons concludes that ‘one simple, dynamo-technology, **low voltage switch** stood between the United States and a major catastrophe.’”



# Circuit variables (T&R Chap 1)

## Charge and Energy

-1 coulomb (C) =  $6.25 \times 10^{18}$  electrons' charge

1 ampere (A) = 1 coulomb/second

Current is a measure of charge passing

Direction of flow is of positive charge

This is important for understanding some devices

Voltage/potential difference/electromotive force/tension

Voltage measures the energy gained by a charge

1 joule(J)/coulomb = 1 volt (V)

Voltage is measured between two points (potential difference)

This is akin to gravitational potential and fluid flow or temperature and heat flow

$$i = \frac{dq}{dt}$$

$$v = \frac{dw}{dq}$$

## Circuit variables (contd)

Power is the rate of energy change per unit time  $p = \frac{dw}{dt}$  watts (W)

Note the chain rule  $p = \left(\frac{dw}{dq}\right)\left(\frac{dq}{dt}\right) = vi$

The instantaneous electrical power associated with a voltage and a current flow is given by the product  $v \times i$

### Passive sign convention

Power is positive when a device absorbs power

Signs are measured as illustrated

“The current variable must be defined so positive current enters the positive voltage terminal of the device”

Note that  $v(t)$  or  $i(t)$  can be negative

In the illustration the current into the device is the negative of that into the rest of the circuit

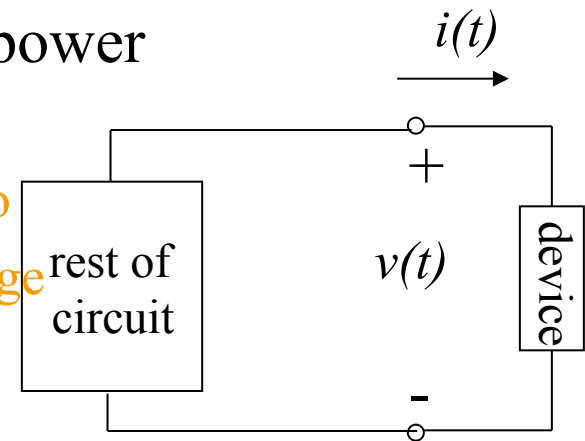



## An example

The figure at right depicts the circuit inside my flashlight

The devices are the battery and the lamp

A voltmeter reads  $v(t)$  is 12V

An ammeter reads  $i(t)$  is  $-1.5\text{A}$

Which device is the battery and which is the lamp? How much power is being consumed by the lamp?

Using the passive sign convention

The power absorbed by device A is  $12 \times -1.5 \text{ W} = -18 \text{ W}$

A is the battery and B is the lamp, which consumes 18W

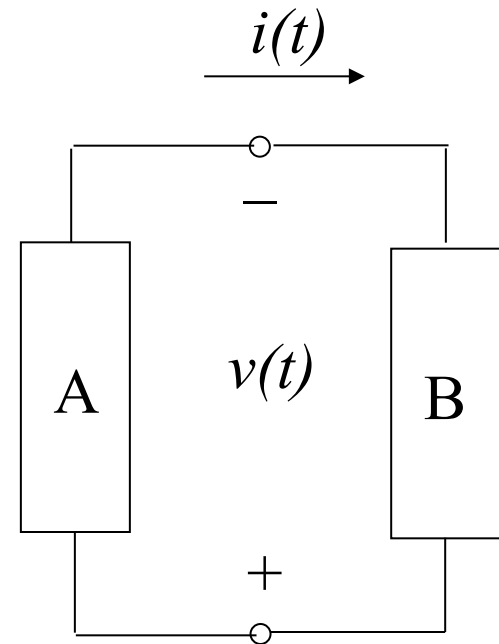

# Circuit variables (contd)

## Ground

Because all voltages are measured between two points, there is no absolute voltage - it is a potential

In circuits we often refer all voltages of points as being relative to a fixed point or *ground* voltage

This is depicted via the  symbol

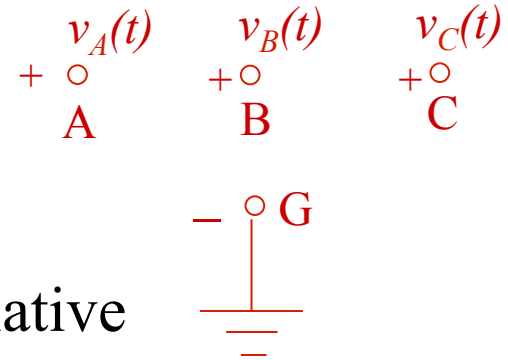

The terms  $v_A$  etc mean the voltage at  $A$  relative to  $G$

This is like referring heights relative to sea level

Gravity is also a potential

Check out the elevator buttons in the Math & App Phys Building!

## Circuit variables (contd)

A *circuit* is a collection of interconnected electrical devices

For us:

All electromagnetic interactions in the circuit take place within the devices (This is a *lumped-parameter* circuit)

The circuit devices are connected together by wires which are ideal

They have the same voltage at both ends instantaneously

They propagate current without loss instantaneously

They may be stretched arbitrarily without changing properties

All circuit devices have at least two terminals and are assumed not to accumulate charge – current in equals current out

A *node* is the junction of terminals of two or more devices

A *loop* is a closed path formed by tracing through an ordered sequence of nodes without passing through any node more than once

# Circuit variables

The important physical circuit variables are currents into and voltages across circuit elements and their associated power consumption or production.

*Circuit analysis* consists of solving for the circuit variables in a given circuit

*Circuit design* or *synthesis* consists of constructing a circuit whose circuit variables exhibit a specified behavior

The *topology* of a circuit is the key structure

It can be stretched and wrapped around without changing circuit variables

Nodes can be stretched and shrunk to cover many terminals

# Circuit Topology

This is the circuit diagram of an audio amplifier

It shows the relationship between parts but not their actual physical location

The ground/earth is likely the chassis or case

The output transistors BD912 and BD911 will need to be attached to an external heat sink

The op-amp OPA604 will be board mounted

The volume control needs to be accessible

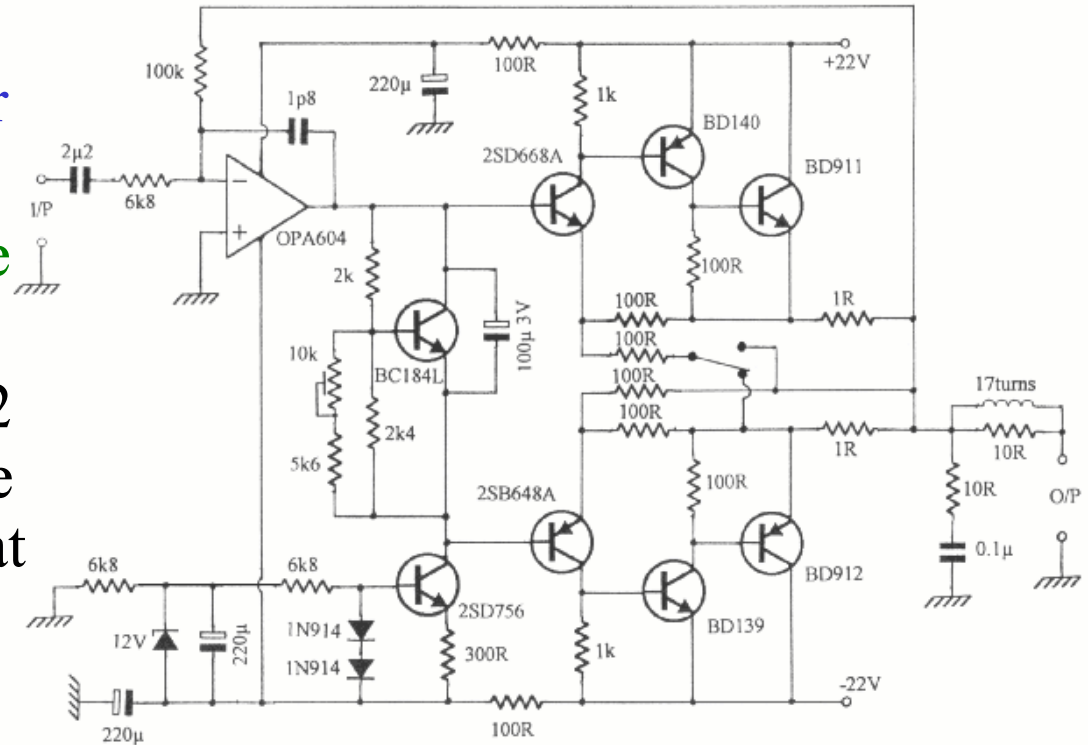

# Circuit Topology – high power amplifier with complementary HEXFETs

## Circuit Diagram

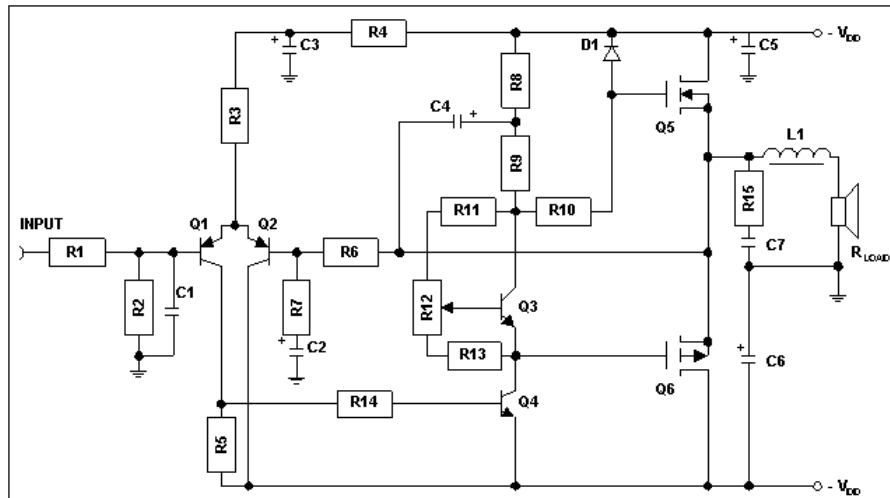

## Circuit Board Layout

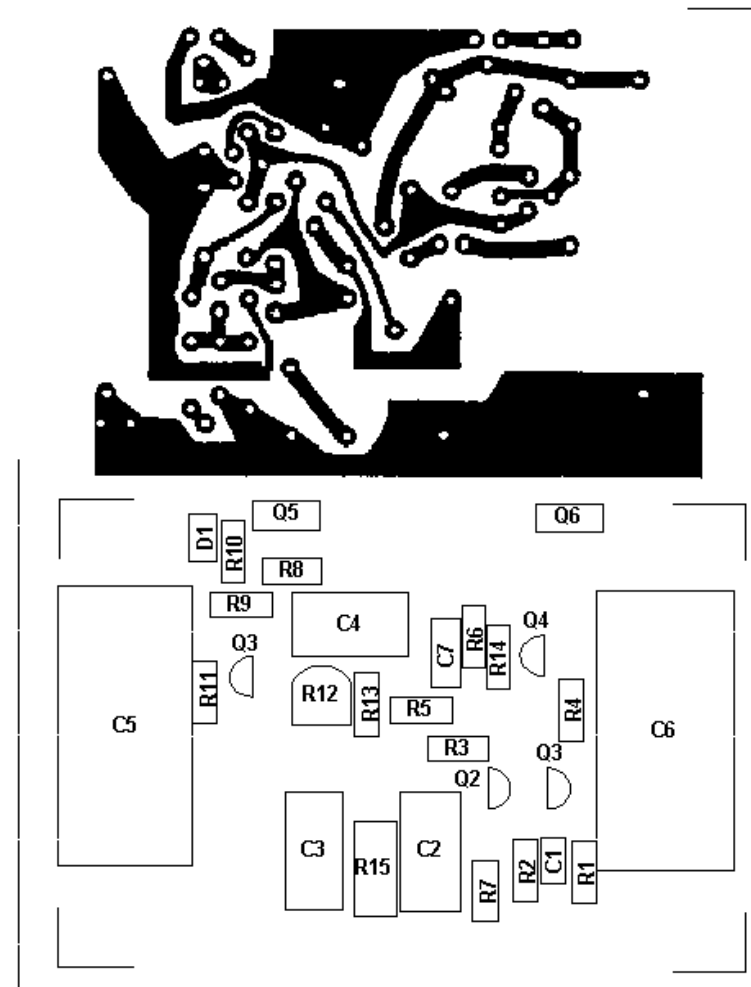

HEXFET – power MOSFET  
from International Rectifier

Figure 2. Amplifier Printed Circuit Board Layout



# Basic Circuit Analysis (T&R Chap 2)

## Kirchoff's Current Law (KCL)

*The algebraic sum of currents entering a node is zero at every instant*

This is a restatement of the principle of conservation of charge  
Alternatively, but not so nice,

*The sum of currents entering a node is equal to the sum of currents leaving a node at every instant*

KCL provides linear constraints between the currents in a circuit

*In a circuit containing a total of  $N$  nodes there are only  $N-1$  independent KCL connection equations*

# T&R, 5th ed, Exercise 2-1 p 22

Write KCL at nodes *A, B, C, D*

Node A:  $-i_1 - i_2 = 0$

Node B:  $i_2 - i_3 - i_4 = 0$

Node C:  $i_4 - i_5 - i_6 = 0$

Node D:  $i_1 + i_3 + i_5 + i_6 = 0$

If  $i_1 = -1\text{mA}$ ,  $i_3 = 0.5\text{mA}$ ,  $i_6 = 0.2\text{mA}$ ,  
find the rest

$i_2 = 1\text{mA}$

$i_4 = 0.5\text{mA}$

$i_5 = 0.3\text{mA}$

Note that we have 4 nodes

But only 3 independent equations

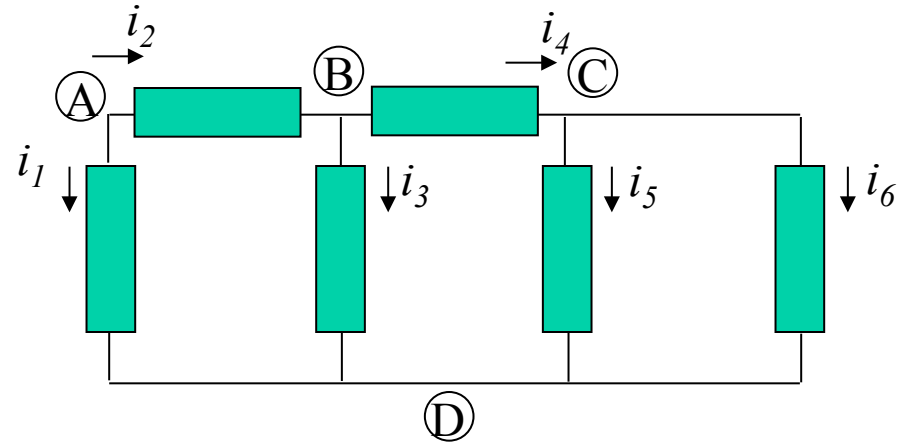

$$\begin{pmatrix} -1 & -1 & 0 & 0 & 0 & 0 \\ 0 & 1 & -1 & -1 & 0 & 0 \\ 0 & 0 & 0 & 1 & -1 & -1 \\ 1 & 0 & 1 & 0 & 1 & 1 \end{pmatrix} \begin{pmatrix} i_1 \\ i_2 \\ i_3 \\ i_4 \\ i_5 \\ i_6 \end{pmatrix} = \begin{pmatrix} 0 \\ 0 \\ 0 \\ 0 \end{pmatrix}$$

# Kirchoff's Voltage Law (KVL)

The algebraic sum of voltages around a loop is zero at every instant

This is really a restatement of voltage as a potential, effectively a statement of the principle of conservation of energy

Example:

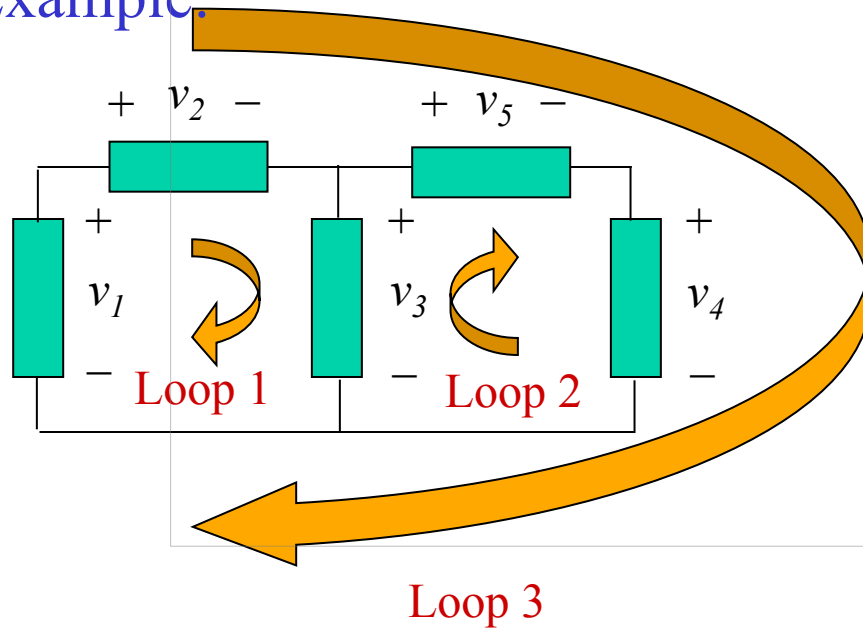

$$\text{Loop 1: } -v_1 + v_2 + v_3 = 0$$

$$\text{Loop 2: } -v_3 + v_4 + v_5 = 0$$

$$\text{Loop 3: } -v_1 + v_2 + v_4 + v_5 = 0$$

$$\begin{pmatrix} -1 & 1 & 1 & 0 & 0 \\ 0 & 0 & -1 & 1 & 1 \\ -1 & 1 & 0 & 1 & 1 \end{pmatrix} \begin{pmatrix} v_1 \\ v_2 \\ v_3 \\ v_4 \\ v_5 \end{pmatrix} = \begin{pmatrix} 0 \\ 0 \\ 0 \end{pmatrix}$$

# Circuit Analysis

One way to consider the analysis of a circuit (i.e. the computation of the currents in and voltage across the circuit elements) is through the specification of constraints on these variables

KCL and KVL provide one set of constraints on circuit variables reflecting connection topology

The  $i$ - $v$  properties of the devices themselves provide further constraints

$N$  nodes and  $E$  circuit elements

$N-1$  independent KCL relations

$E-N+1$  independent KVL relations (number of independent loops)

$E$  independent  $i$ - $v$  characteristics

$2E$  circuit variables

If we keep to linear devices then we have linear circuit analysis

$2E$  Linear algebraic equations for  $2E$  variables

# Linear Circuit Elements

## Linearity in $v$ - $i$ relations

Doubling  $v$  doubles  $i$  and vice versa  $i = \alpha v$

Straight lines in  $i$ - $v$  plane

Note that  $i = \alpha v + \beta$  describes an *affine* relation

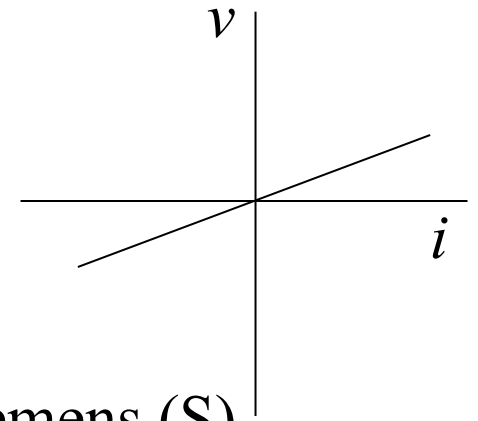

## Resistor

$v = Ri$  or  $i = Gv$  Ohm's Law

$R$  resistance in ohms ( $\Omega$ ),  $G$  conductance in siemens (S)

Power  $P = i^2 R = v^2 / R = v^2 G$

A resistor always absorbs power –  $i$ - $v$  line has positive slope

## This is an instantaneous linear element

We will look at circuit elements with memory like  $C$  and  $L$  later in the course

# Time out puzzle

We have three lamps – red, green and blue – connected to three switches as in the diagram

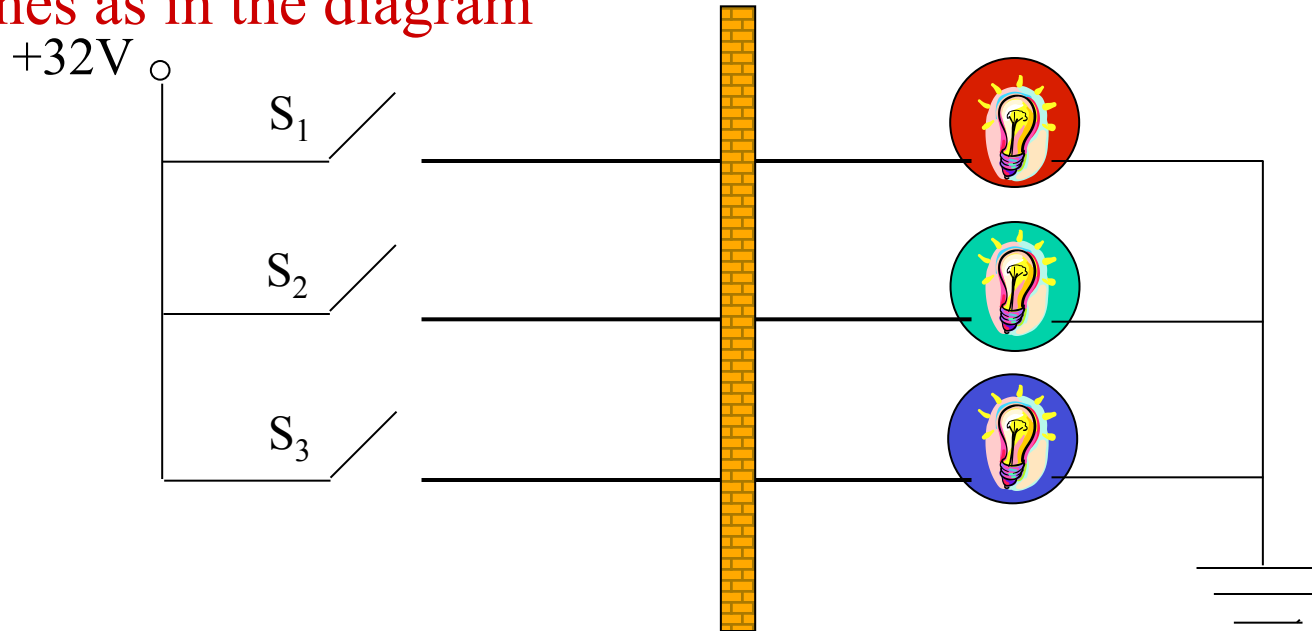

The lamps are outside the switch room and we are alone

What single test can we perform by playing with the switches to determine which switch is connected to which light?

I know of two solutions, one of physicists one of engineers



# Linear Circuit Elements (contd)

## Independent Voltage and Current Source (IVS and ICS)

IVS  $v=v_s$  for any  $i$

ICS  $i=i_s$  for any  $v$

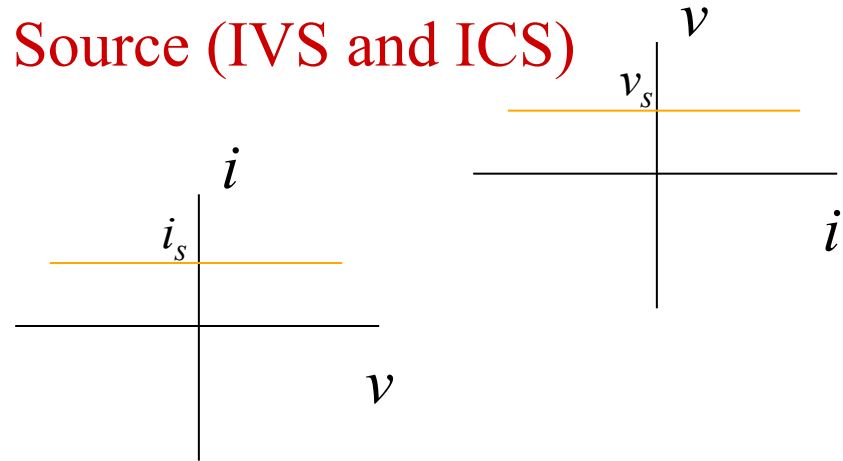

These are affine elements rather than linear. But we admit them here.

## Open circuit and short circuit – variants of ICS and IVS resp.

Open circuit  $i=0$  for any  $v$

Same as  $R=\infty$

Short circuit  $v=0$  for any  $i$

Same as  $R=0$

These are truly linear since the curves pass through (0,0)

## Switches – either o.c. or s.c.

## Example 2-10 (T&R, 5th ed, p. 31)

Write a complete set of equations  
for each element

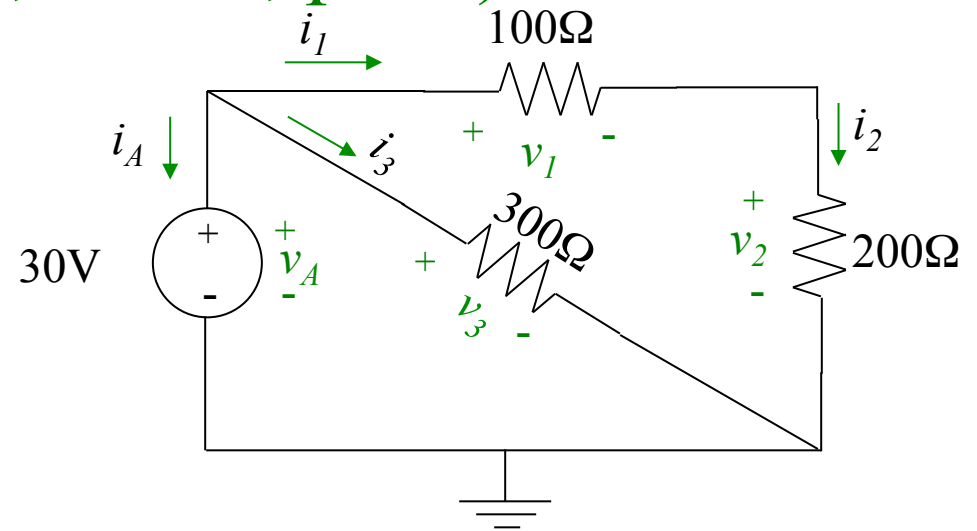

Write a complete set of connection equations

Solve these equations for all currents and voltages

## Example 2-10 (T&R, 5th ed, p. 31)

Write a complete set of equations  
for each element

$$v_A = 30V;$$

$$v_1 = 100i_1;$$

$$v_2 = 200i_2;$$

$$v_3 = 300i_3;$$

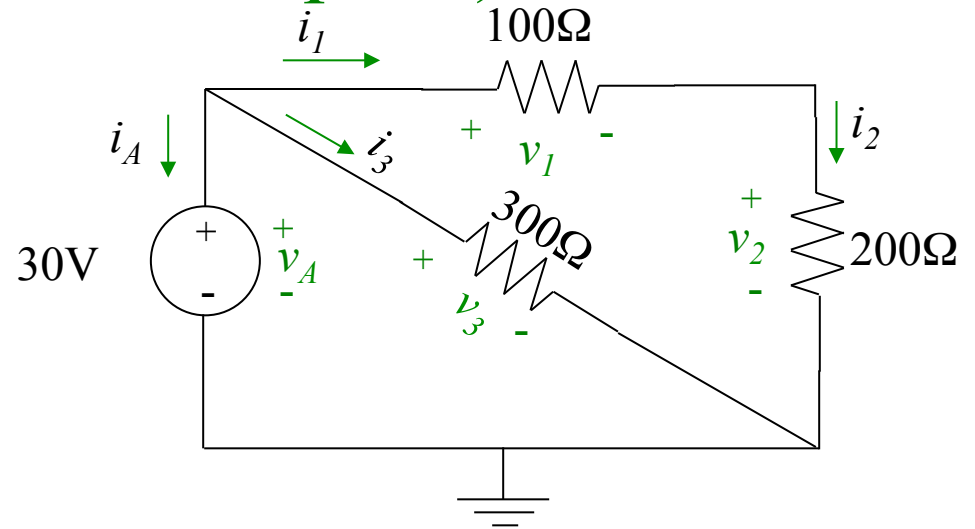

Write a complete set of connection equations

$$-i_A - i_1 - i_3 = 0; \quad i_1 - i_2 = 0; \quad -30 + v_3 = 0; \quad v_1 + v_2 - v_3 = 0;$$

Solve these equations for all currents and voltages

$$v_A = 30V; \quad v_1 = 10V; \quad v_2 = 20V; \quad v_3 = 30V;$$

$$i_A = -200mA; \quad i_1 = i_2 = i_3 = 100mA;$$

# All you ever wanted to know about resistors ...

Resistors are color coded to indicate their value

Black	Brown	Red	Orange	Yellow	Green	Blue	Violet	Grey	White
0	1	2	3	4	5	6	7	8	9

and tolerance

5%	10%	20%
Gold	Silver	Empty

This is a 1KΩ resistor with 5% tolerance

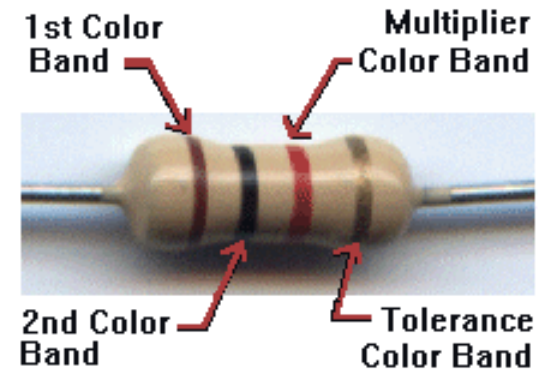

Resistors come at standard values (e.g., at 10% tolerance)

1	1.2	1.5	1.8	2.2	2.7	3.3	3.9	4.7	5.6	6.8	8.2	Nominal
.9	1.08	1.35	1.62	1.98	2.43	2.97	3.51	4.23	5.04	6.12	7.38	Lower
1.1	1.32	1.65	1.98	2.42	2.97	3.63	4.29	5.17	6.16	7.48	9.02	Upper

# Even more than you ever wanted to know about resistors ...

## The distribution of resistances

Why should this be so?

## How can we get a $258.3\Omega$ resistor?

Keep testing the ones in the box

A really finely tunable potentiometer  
(variable resistor) – a *trimpot*

A coarsely tunable potentiometer in parallel with a lower  $R$

Make one from high precision components

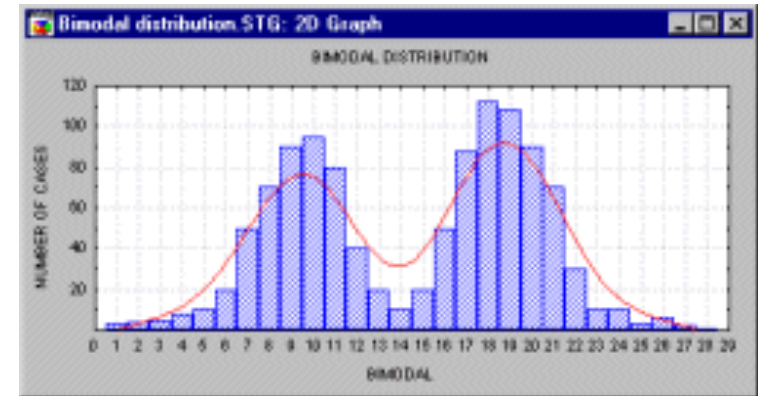

## Another important characteristic of $R$ is the power rating

Why?