

# Equivalent Circuits & Reduction (T&R Chap 2,3)

## Circuit Equivalence

Two circuits are equivalent if they have the same  $i$ - $v$  characteristics at a specified pair of terminals

Terminal = external connection to two nodes = port

Our aim is to simplify analysis replacing complicated subcircuits by simpler equivalent circuits

## Example

Association of resistors

# Equivalent Circuits & Reduction (T&R Chap 2,3)

## Resistors in Series

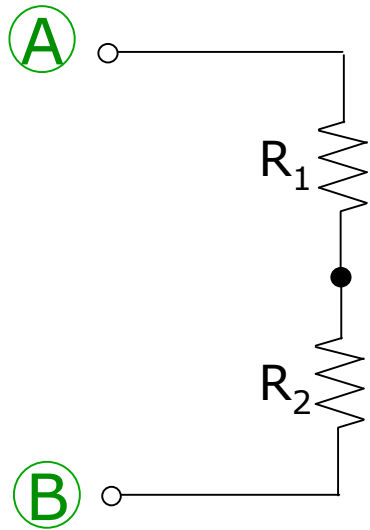

$$R_{EQ} = R_1 + R_2$$

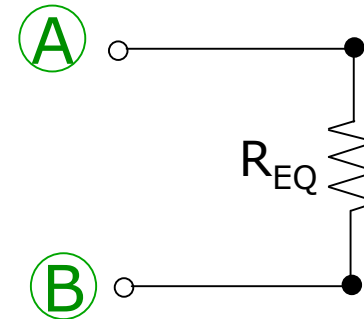

## Resistors in Parallel

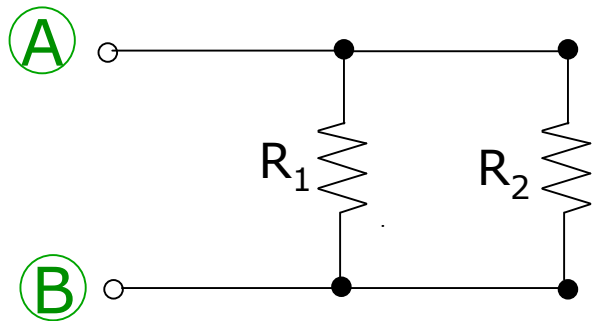

$$R_{EQ} = \frac{1}{\frac{1}{R_1} + \frac{1}{R_2}} = \frac{R_1 R_2}{R_1 + R_2}$$

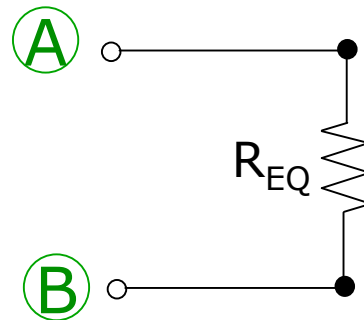

## Example 2-11 (T&R p. 34)

Consider the circuit

Compute equivalent ccts  
from AB and from CD

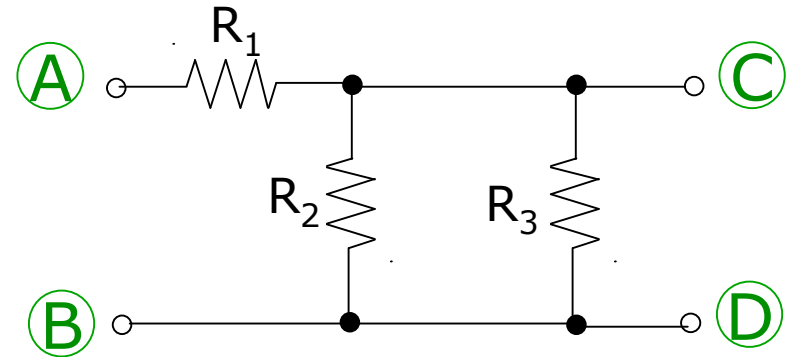

$$R_{EQCD} = R_2 \parallel R_3 = \left( \frac{1}{R_2} + \frac{1}{R_3} \right)^{-1} = \frac{R_2 R_3}{R_2 + R_3}$$

$$R_{EQAB} = R_1 + R_2 \parallel R_3 = R_1 + \frac{R_2 R_3}{R_2 + R_3}$$

# Example 2-10 (T&R p. 31) Revisited

Can you find  $i_A$ ?

All you need to know is

$$v_A = 30V$$

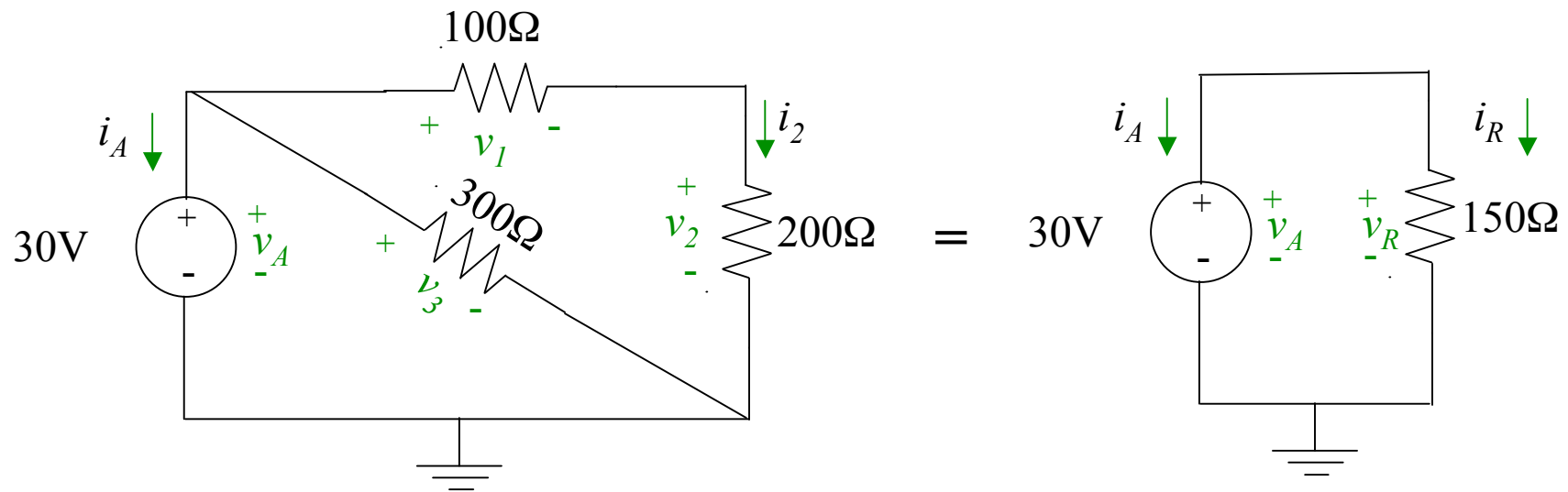

Answer

$$i_A = -i_R = -30/150 = -200 \text{ mA};$$

# Equivalent ccts

Equivalent ccts for resistive networks are familiar reductions of parallel and series connections

The equivalent cct depends on the port

From an external view the cct could be replaced by its equivalent

The internal cct variables are now unavailable

How would you compute them?

Could we substitute for the cct below?

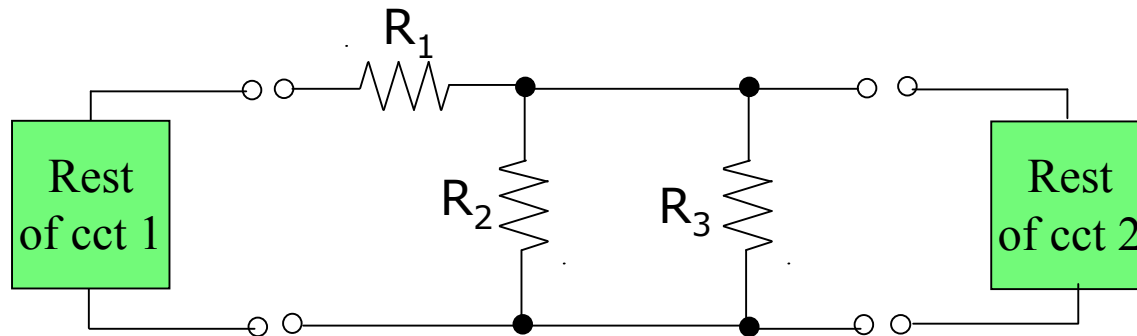

# Equivalent sources

*i-v* relationships determine equivalence

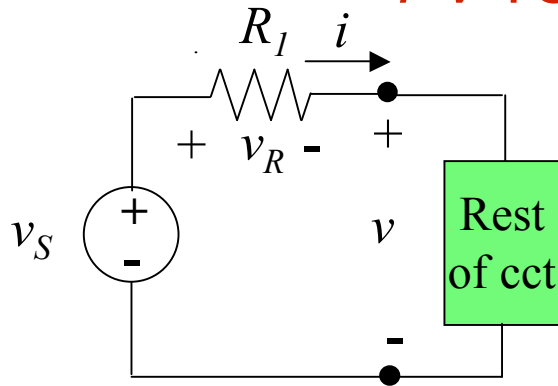

$$i = -\frac{v}{R_1} + \frac{v_S}{R_1}$$

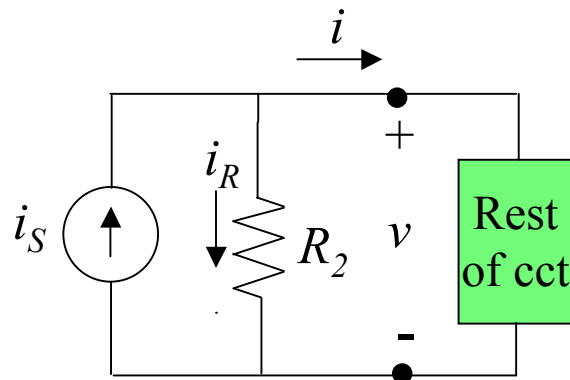
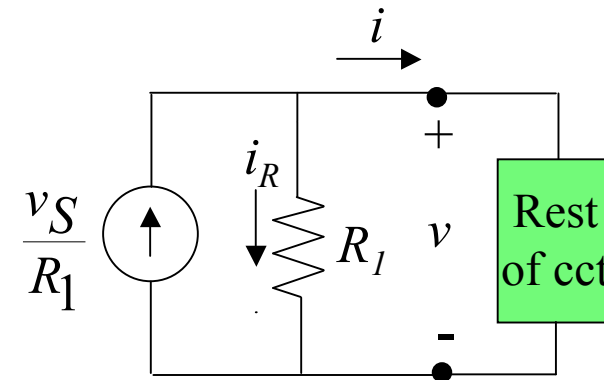

$$i = -\frac{v}{R_2} + i_S$$

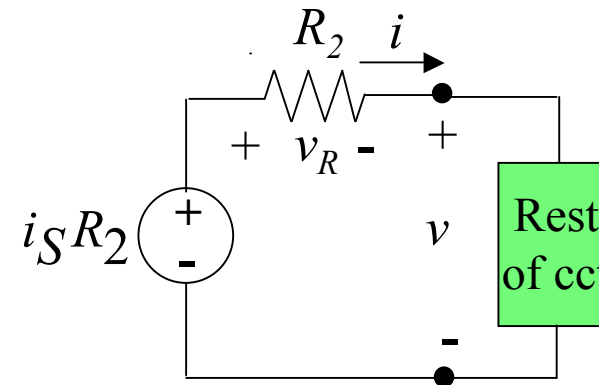

# Equivalent Sources (cntd)

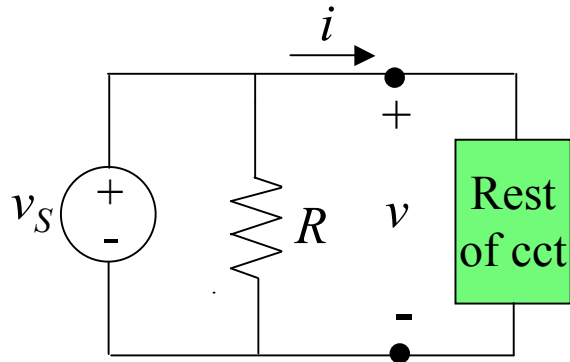

$$v = v_S$$

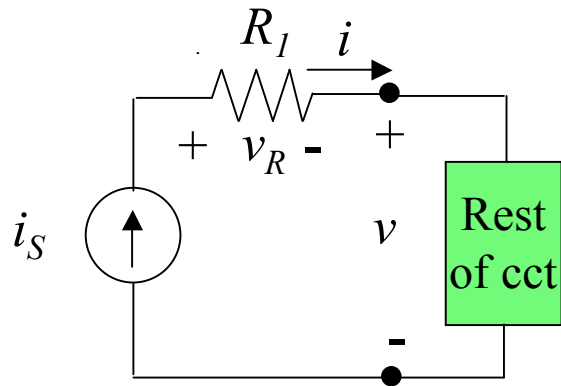
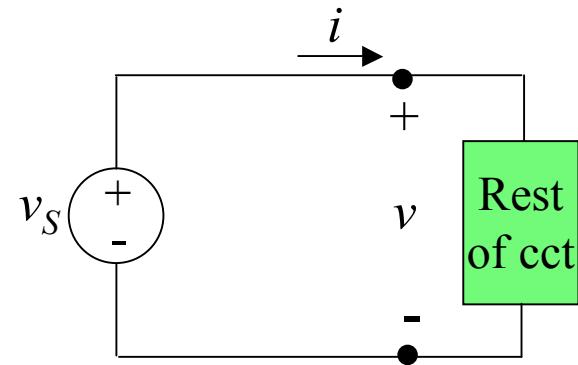

$$i = i_S$$

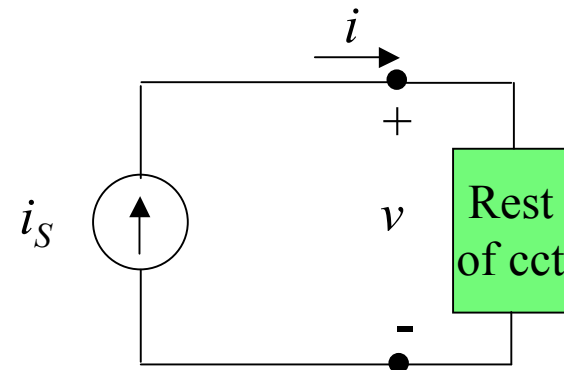

# Equivalent Sources (cntd)

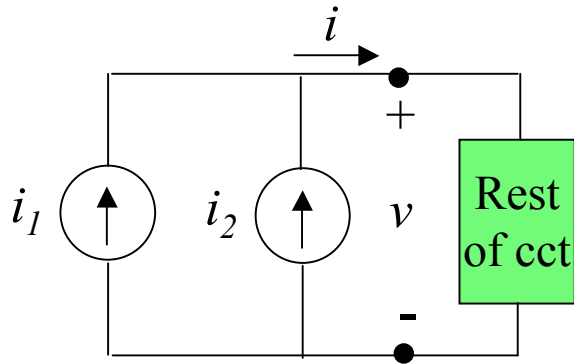

$$i_S = i_1 + i_2$$

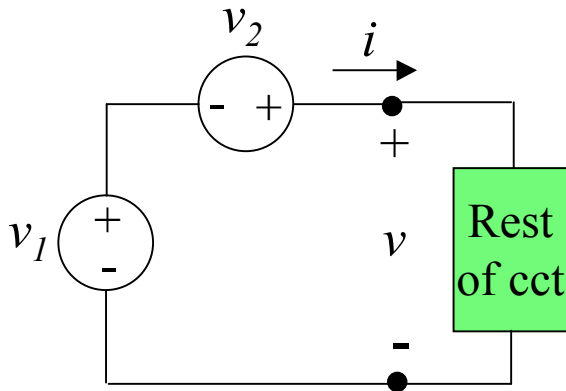
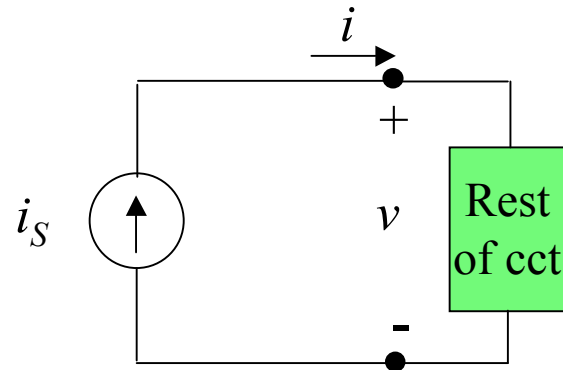

$$v_S = v_1 + v_2$$

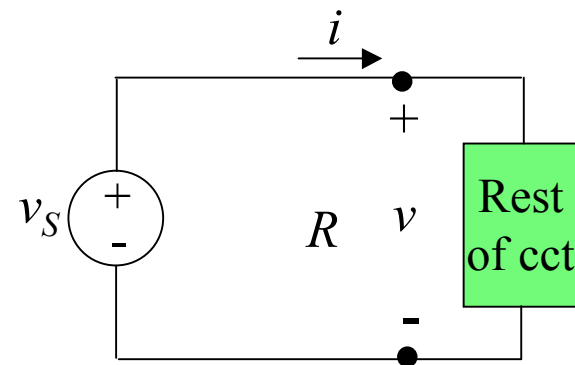



## Equivalent Sources (cntd)

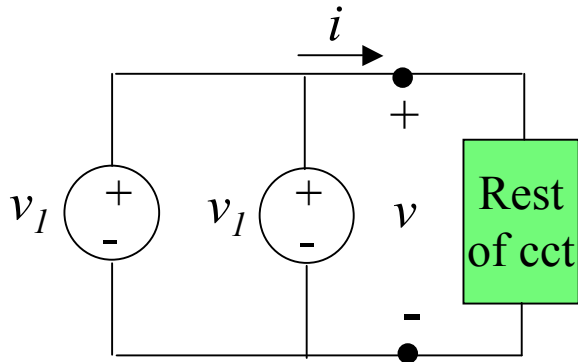

**Only works if  $v_1 = v_2$   
then  $v_S = v_1 = v_2$**

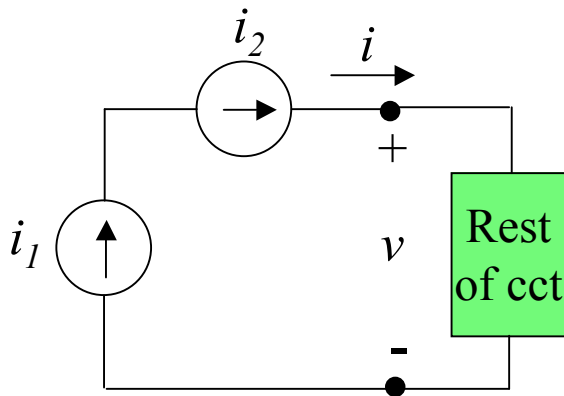
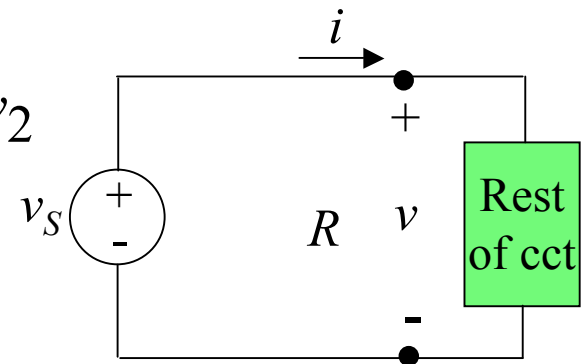

**Only works if  $i_1 = i_2$   
then  $i_S = i_1 = i_2$**

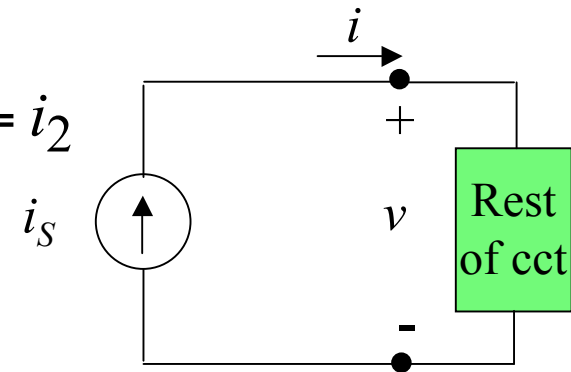

# Circuit Reduction

For ladder networks

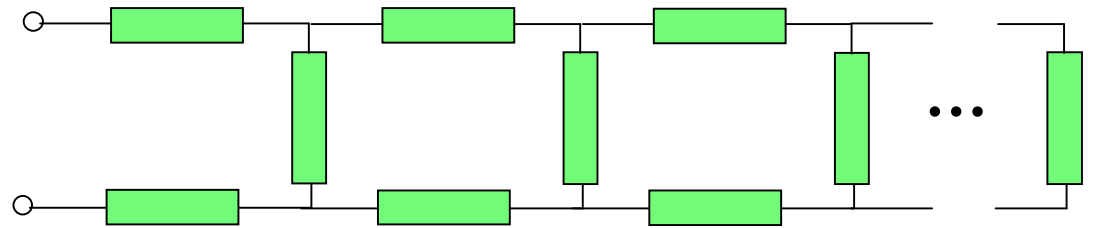

Reduce complexity by successively replacing elements by their equivalents

What happens with three elements in series or in parallel?

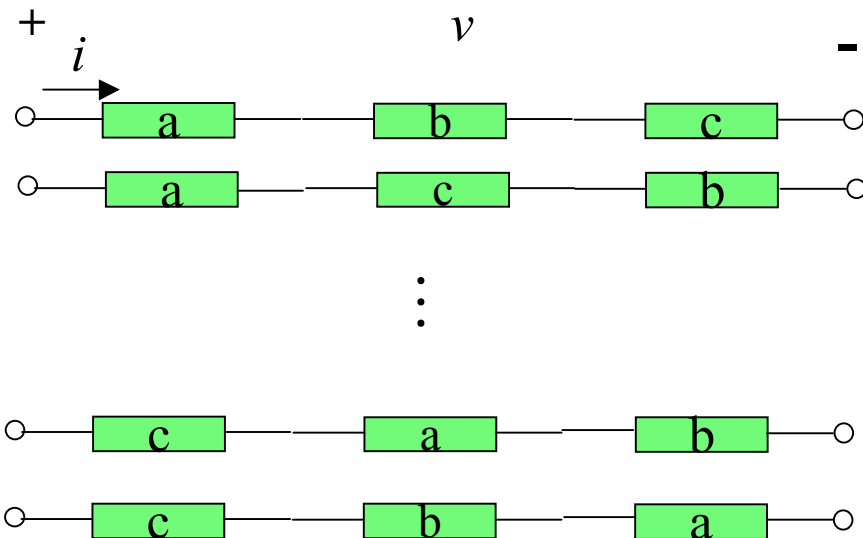

They are all equivalent  
We can commute elements

# T&R Example 2-22 p 49

Find  $v$

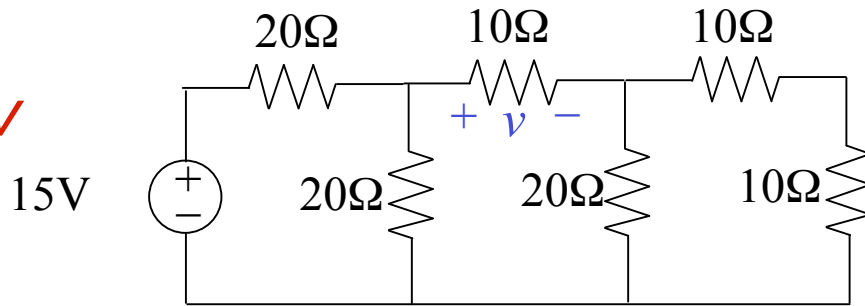

Reduce the left end

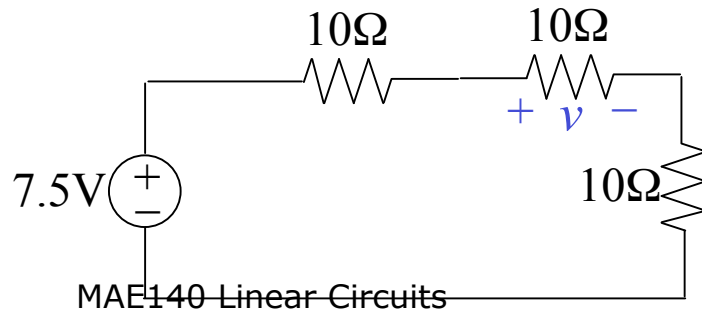
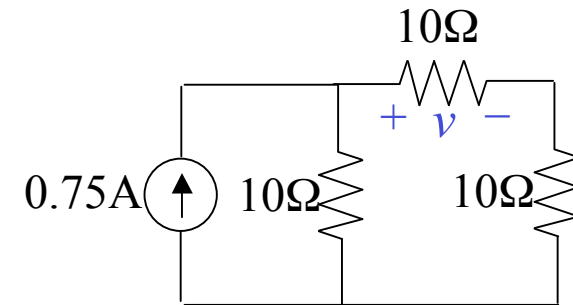
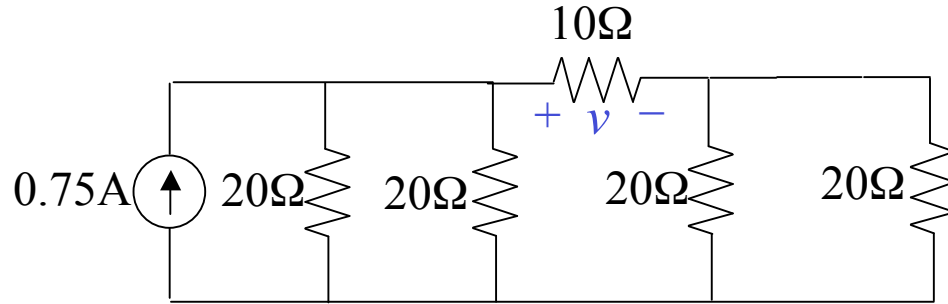
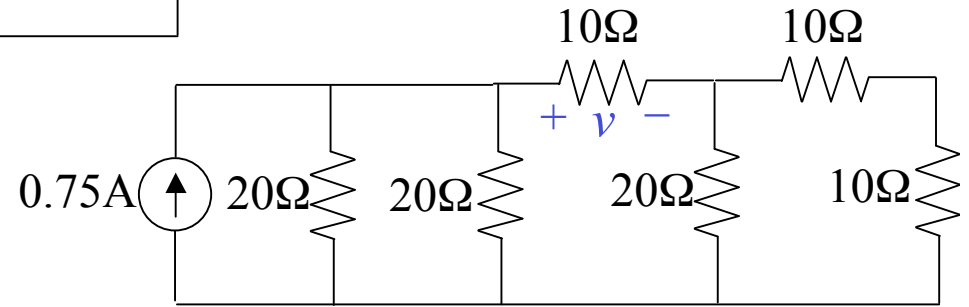

$$v = 2.5V$$

# Voltage & Current Dividers

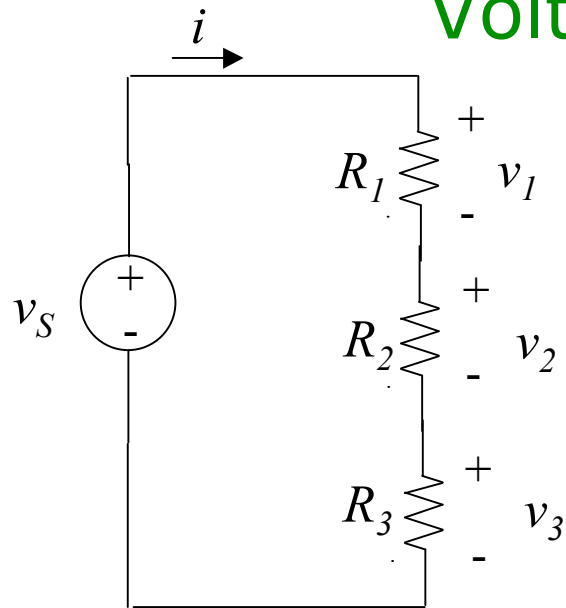

$$R_{total} = R_1 + R_2 + R_3$$

$$v_1 = \frac{R_1}{R_{total}} v_S; \quad v_2 = \frac{R_2}{R_{total}} v_S; \quad v_3 = \frac{R_3}{R_{total}} v_S$$

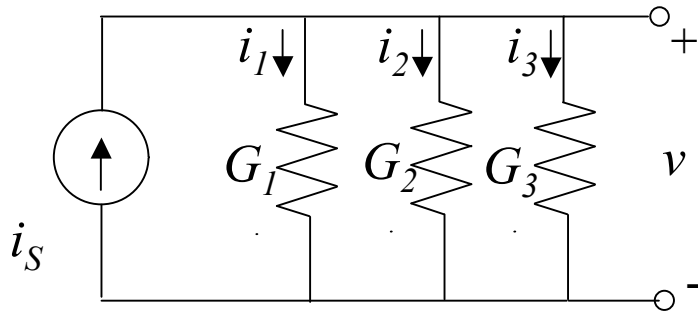

$$G_{total} = G_1 + G_2 + G_3$$

$$i_1 = \frac{G_1}{G_{total}} i_S; \quad i_2 = \frac{G_2}{G_{total}} i_S; \quad i_3 = \frac{G_3}{G_{total}} i_S$$

$$G_i = \frac{1}{R_i}$$

# Voltage Dividers

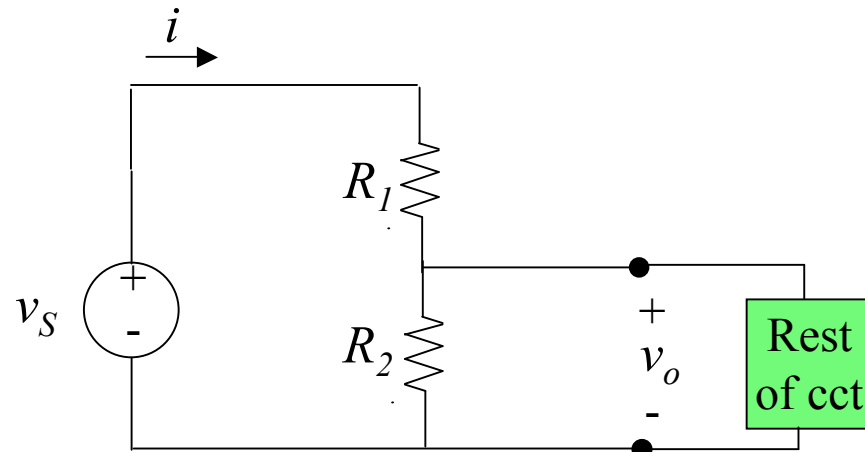

Often we use a voltage divider to provide an input voltage to a cct element

When would this work?

When the "rest of cct" does not draw much current compared to  $R_2$

Why is this?

What is it asking of the equivalent of the rest of cct?

Note that this is a very common circuit used to "bias" a transistor to an operating voltage

# Thévenin and Norton Equivalent Ccts

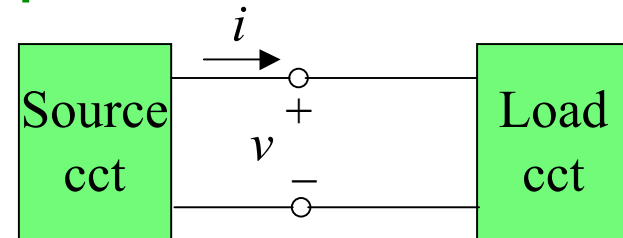

## Thévenin's Theorem

If the source cct in a two-terminal interface is linear, then the interface signals  $v$  and  $i$  do not change when the source cct is replaced by its Thévenin equivalent

Note: nobody says the load must be linear!

## Thévenin Equivalent Circuit

$v_T$  is the open-cct voltage of source  
 $R_T$  is evaluated from short-cct current

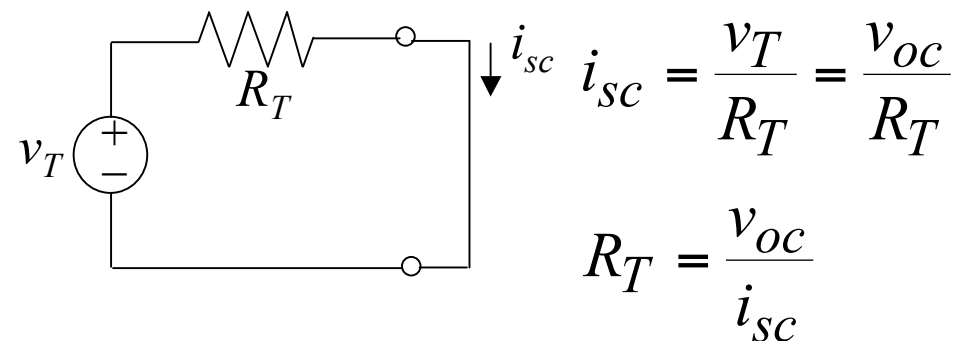
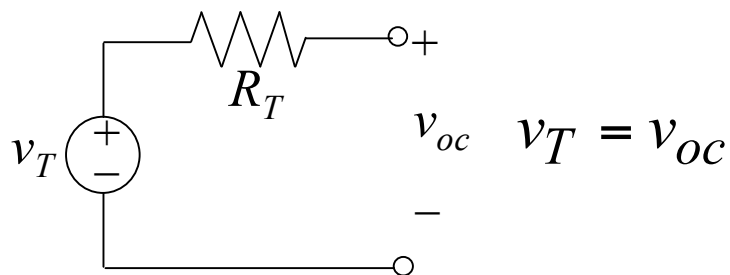
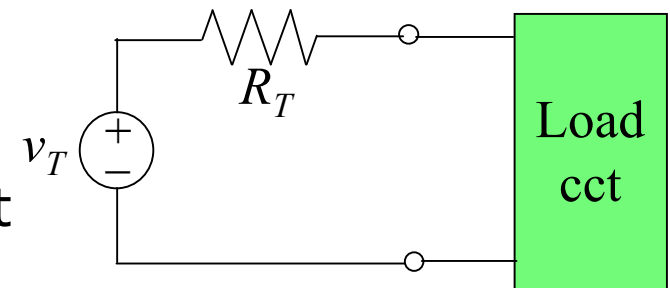

# Thévenin's Theorem Proof

Linearity of the Source cct is the key – superposition

Hook up a test current source to cct

$i_{test}$  yields voltage  $v_{test}$

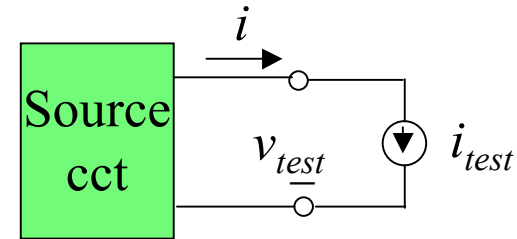

Part I,  $i_{test,1} = 0$  but  $i$  and  $v$  sources  
in Source cct left ON then  $v_{test,1} = v_{oc} = V_T$

Part II,  $i_{test,2} \neq 0$  and sources left OFF  
in Source cct then  $v_{test,2} = -R_t i_{test,2}$

By linearity of the Source cct  $v_{test}$  is the sum of these parts  
for any choice of  $i_{test}$

This establishes the  $i$ - $v$  relationship for any load cct

# Thévenin and Norton Equivalent Ccts

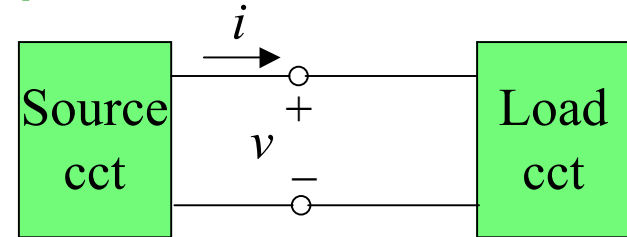

## Norton's Theorem

If the source cct in a two-terminal interface is linear, then the interface signals  $v$  and  $i$  do not change when the source cct is replaced by its Norton equivalent

## Norton Equivalent Circuit

$v_T$  is the open-cct voltage of source  
 $R_T$  is evaluated from short-cct current

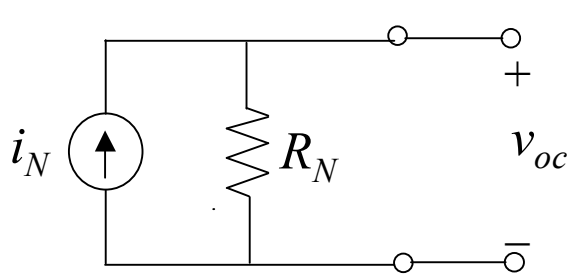
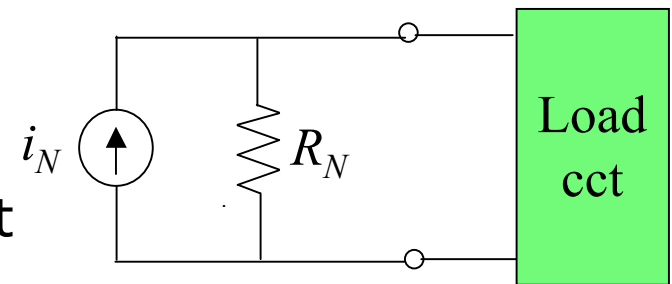

$$v_{oc} = i_N R_N = i_{sc} R_N$$

$$R_N = \frac{v_{oc}}{i_{sc}} = R_T$$

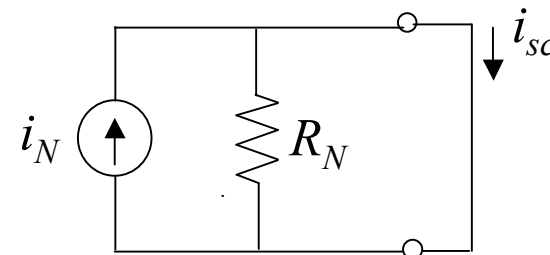

$$i_N = i_{sc}$$

$$= \frac{v_T}{R_N}$$

$$= \frac{v_T}{R_T} \quad 38$$



## Example 3-16 p.110 T&R

Find the Thévenin and Norton equivalent ccts of

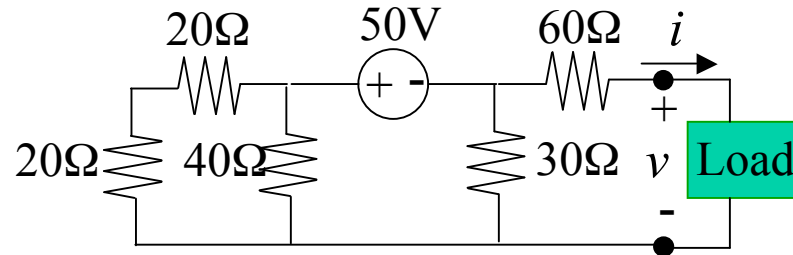

Find the voltage, current and power if load is 50Ω

**Answer:**  $v_T = -30V$ ;  $i_N = -417mA$ ;  $R_N = R_T = 72\Omega$

$V = -12.3V$ ;  $i = -246mA$ ;  $p = 3.03W$